

The machine is suitable to string one rope.
The bull-wheel grooves are made of thermally treated steel

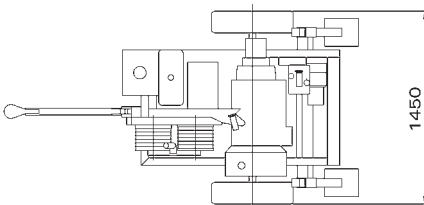

Certified Quality System
ISO 9001:2000

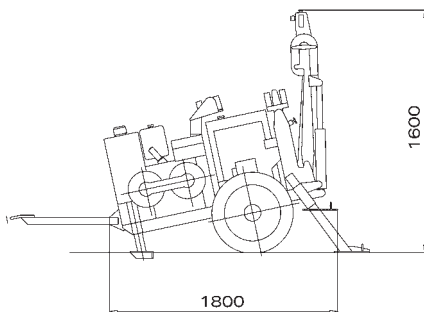

M = 850 kg

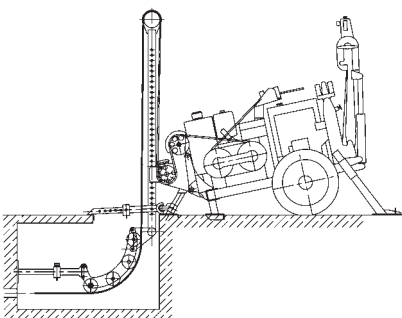

OPT 110

PERFORMANCE

Max pull	35 kN
Speed at max pull	1.2 km/h
Max speed	3.6 km/h
Pull at max speed	12 kN

Note: the basic machine performance is calculated at 20°C and at sea level

CHARACTERISTICS

Bull-wheel diameter	325 mm
Max rope diameter	13 mm

ENGINE

Diesel	25 kW
Cooling system	water
Electrical system	12 V

HYDRAULIC TRANSMISSION

Closed hydraulic circuit for stepless speed variation in both rotating directions



DLR 100

CONFIGURATION

Negative self-acting hydraulic brake

Hydraulic dynamometer with set-point and automatic control of maximum pull

Hydraulic oil cooling system

Control instruments for hydraulic system and Diesel engine

Rigid axle for towing at max speed of 30 km/h

Built-in self-loading reel winder with automatic level wind, suitable for standard reel mod. BOF 010 and BOF 020

Mechanical actuated front plough stabiliser

EQUIPMENT ON DEMAND

050 Pull pre-setting system

OPTIONAL

053 Equipment for electronic firing parameter recorder

110 Rod with roller device for underground cables

AXR 001 Extra shaft

DLR 100 Electronic firing parameter recorder

111 Cable guide pivot pulley suitable for work in manhole and into ditch



Opt. 111